

**DESCRIPTION:** Straight type, grey cast iron body, metal seated screw down stop valve with rising stem, bolted bonnet. Raised face flanged connection.

**APPLICATION:** Aboard ships for hot and cold water and oil.  
Start/stop and throttling of: Sea water, water and oils etc.

**VARIATIONS:** Can be supplied with regulating disc and non return disc.  
Stainless steel trim. With open/close indication

**STANDARD & DESIGN:**

Design Code: DIN 86251 Stop Type (DIN 3356)  
Inspection Std.: -  
End Std.: EN 1092-2/B (DIN 2501)  
Face to Face Std.: EN 558 series 1 (DIN 3202 F1)  
Flanges drilled: PN16 (DN15-DN150)  
PN10 (DN200-DN600)  
PN16 (DN15-DN150)  
PN10 (DN200-DN250)  
PN6 (DN300-DN350)  
PN4 (DN400-DN600)

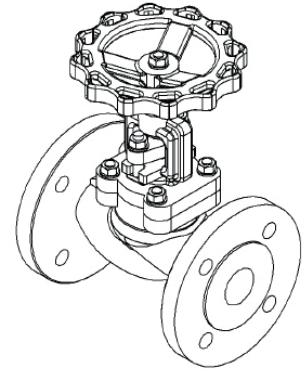

Pressure & Temperature ranges:

Bore	Working Pressure(Bar)	
	120°C	180°C
DN15-DN150	16	10
DN200-DN250	10	6
DN300-DN350	6	4
DN400-DN600	4	2

No	Part	Material	Code
1	Body	Cast Iron	EN-GJL250
2	Bonnet	Cast Iron	EN-GJL250
3	Seat	Bronze	CuSn5Zn5Pb5-C
4	Disc(<=65) (>=80)	Bronze Nodular Cast Iron	CuSn5Zn5Pb5-C EN-GJS400-18-LT
5	Stem	Brass	CuZn35Ni3Mn2AlPb
6	Gland Packing	Graphite	-
7	Bonnet Gasket	Graphite	-
8	Stud Bolt	Steel	-
9	Nut	Steel	-
10	Hand Wheel	Cast Iron	EN-GJL250

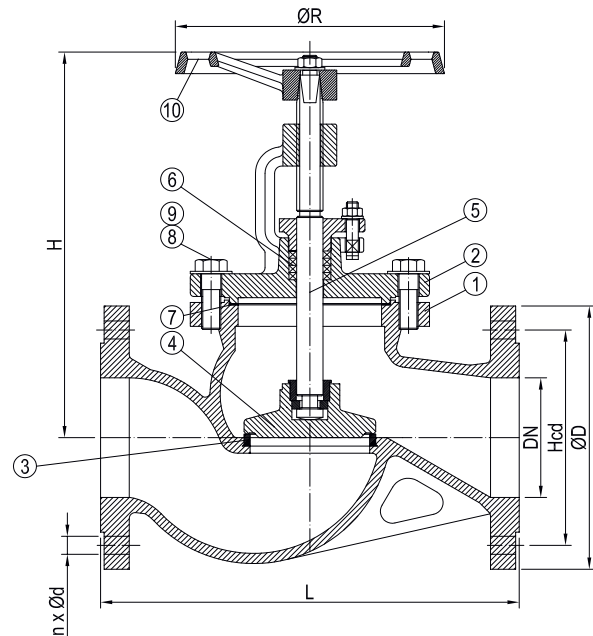

DN	n x ød	Hcd	øD	L	H	øR	Kg
15	4x14	65	95	130	165	120	4
20	4x14	75	105	150	165	120	4
25	4x14	85	115	160	175	140	5
32	4x18	100	140	180	180	140	7
40	4x18	110	150	200	220	160	11
50	4x18	125	165	230	230	160	13
65	4x18	145	185	290	245	180	18
80	8x18	160	200	310	295	200	25
100	8x18	180	220	350	330	225	35
125	8x18	210	250	400	365	250	55
150	8x22	240	285	480	420	300	75
200	8x22	295	340	600	510	400	135
250	12x22	350	395	730	600	520	215
300	12x22	400	445	850	670	520	305
350	16x22	460	505	980	755	640	405
400	16x26	515	565	1100	835	640	550
450	20x26	565	615	1200	920	640	690
500	20x26	620	670	1250	970	640	835
600	20x30	725	780	1450	1200	640	1050